



ARCHITECTURAL SERIES SYSTEM Maintenance & Cleaning Guide

REGULAR MAINTENANCE IS NOT REQUIRED.

The following steps should be done by a person knowledgeable of the hazards involved.

To verify the system is working:

If you want to verify the panels are working, simply turn them on. In the event that you do not feel any heat coming from the heater then do the following:

1. Check the thermostat or controls to make sure they are working.
2. If the thermostat or controls are working, check the electrical breaker to ensure there is power to the thermostat/controls.
3. Then verify that there is power going to the heating panels at the correct voltage.
4. The last step is to disconnect the heaters (remember to turn off all the power beforehand) and do an ohms test of the heaters themselves.
 - a. If there is no ohm reading then the panel is no longer working (this is very rare so we suggest you verify the ohms reading at least twice).
 - b. If you have an ohm reading, record it and call us to verify everything is within specifications.
 - c. Reconnect the heating panel and turn on the system. If there is still no heat and the ohm readings are correct, then it is an electrical supply problem, not a heating panel problem.

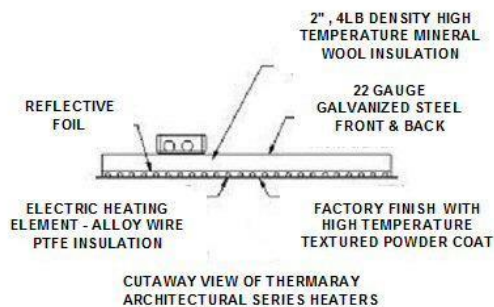
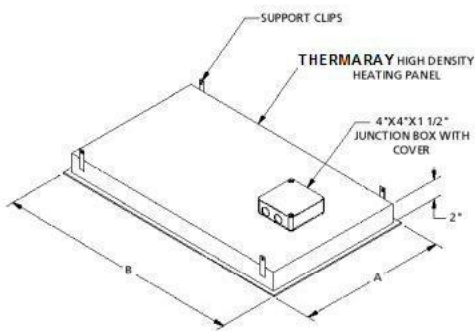

The difference between heat and comfort

Plaster Frame Kit Option

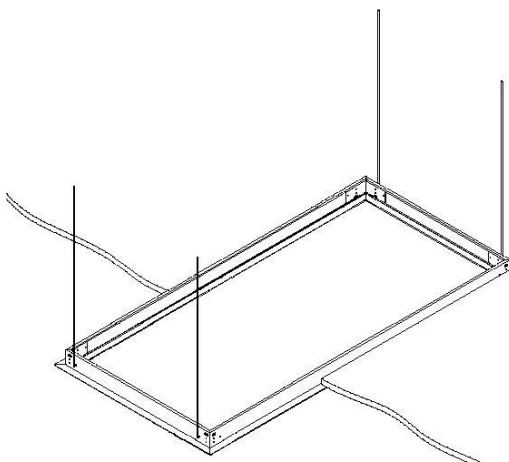

CLEANING

ThermaRay Architectural Series heaters are painted using a high temperature anti-bacterial powder coat finish. The powder coat finish is highly durable. To clean the painted surface, water and a mild detergent is all that is needed. Oil and other contaminants often found in industrial or warehouse installations are more difficult to remove if not impossible. Stronger detergents can be used but it is recommended that you test a section of a panel first. Rinse thoroughly to remove any soap residue.

Do not use abrasives or harsh chemicals as this may remove the paint. It will not affect the operation of the panel. However, the appearance of the panel will be permanently changed.

RE-PAINTING THE FRAMES AND HEATERS.

Frames: The frame can easily be repainted using latex based paint only. They have a powder coat finish and will need preparation according to the paint manufacturer.

Heaters: The heaters cannot be easily re-painted. They require a high temperature paint. Regular paint will peel and not last long. It is possible to purchase high temperature paint at most paint stores. Please follow the paint manufacturer's instruction. Although re-painting will not affect the operation of the heater, we cannot guarantee the aesthetic finish. Please feel free to contact us if you have questions in this regard.



Toll Free: +1 (888) 992-2889
Montreal: +1 (438) 388-7700
Ottawa-Kingston: +1 (613) 869-7425
Toronto: +1 (647) 849-5629
info@petrabuildingsolutions.com
www.petrabuildingsolutions.com